

# Hydrogen Flow Meter

For Fuel Cell Anode Inlet & Recirculation

Prototype Phase

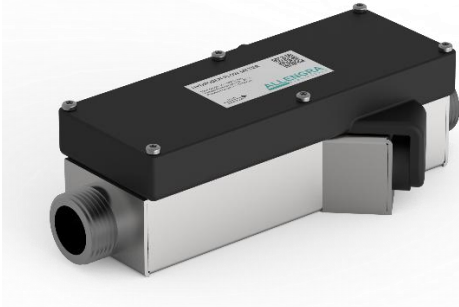

## Overview

- For **Pure** Hydrogen H<sub>2</sub> and Hydrogen **Mixtures**
- Accuracy  $\pm 3\%$  of measured value
- **Mass Flow** Determination
- Recirculation **Concentration** Determination H<sub>2</sub>-N<sub>2</sub>-H<sub>2</sub>O
- **Stainless Steel** Sensor Body
- **CAN & Modbus** Communication
- Integrated **Temperature** and **Pressure** Sensor
- Integrated **Humidity** Sensor
- Suitable for **dry & wet** gases up to 100 % RH
- **Robust** against impurities and dirt

## Operating conditions

Media	Pure Hydrogen H <sub>2</sub> , H <sub>2</sub> -N <sub>2</sub> -H <sub>2</sub> O Mixture <i>others on request</i>
Operating temperature	-20 – 85 °C
Operating pressure	0.8 – 20 bar(a)
Burst pressure	30 bar(g)
Operating humidity	0 – 100 % RH
IP code	acc. to IP 44
Leakage rate	≤ 10 nccm/h

## Materials

Wetted parts	Stainless Steel 316L / 1.4404, Stainless Steel 303 / 1.4305, Stainless Steel 304 / 1.4307, Silica, Photopolymer <i>Conformity of all materials for hydrogen applications confirmed by long-term tests or by the manufacturer</i>
Non-wetted parts	Rapid Prototyping Photopolymer Resin

## Features

Mass Flow Determination	Mass flow determination using ideal gas law based on measurements of volume flow, temperature, and pressure.
Gas Composition Determination	Gas composition determination of H <sub>2</sub> -N <sub>2</sub> -H <sub>2</sub> O gas mixtures; ideal for PEM fuel cell <b>anodic recirculation</b> control.

# Hydrogen Flow Meter

For Fuel Cell Anode Inlet & Recirculation

## Flow Measurement

Measurement technology	Ultrasonic		
<b>Dimension</b>	<b>3/4"</b>	<b>1"</b>	<b>1 1/2"</b>
Volume Flow Range	10 - 1000 l/min	20 - 1700 l/min	40 - 3400 l/min
Volume Flow Accuracy	±3 % of measured value *		
Repeatability	±1 % of measured value		
Response time	< 0.5 s		

Accuracy funnel

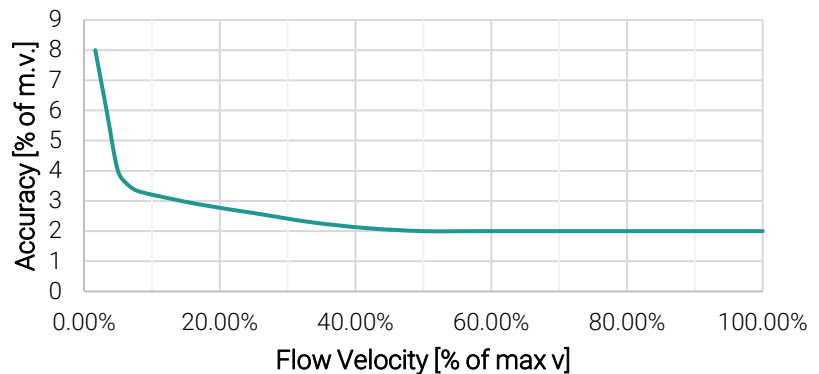

\* Accuracy specification per accuracy funnel, assuming turbulence-free flow conditions (refer to [installation notes](#)).

## Temperature Measurement

Measurement element	PT1000 class B
Measurement range	-20 - 110 °C
Accuracy	±1 K
Repeatability	±0.5 K
Response time T09	< 5 s

## Pressure Measurement

Measurement element	Ceramic pressure sensor
Measurement range	0 - 20 bar(a)
Accuracy	2 % of measured value
Repeatability	1 % of measured value
Response time	< 0.5 s

## Humidity Sensor

Measurement technology	Capacitive, polymer-based
Humidity range	0 - 100 % RH
Humidity Accuracy	±3 %
Repeatability	±0.5 %
Response time	< 10 s

## Mass Flow Determination

Method Based on ideal gas law

Flow Range vs. medium pressure

Max. measurable mass / normal volume flow increases with higher medium pressure

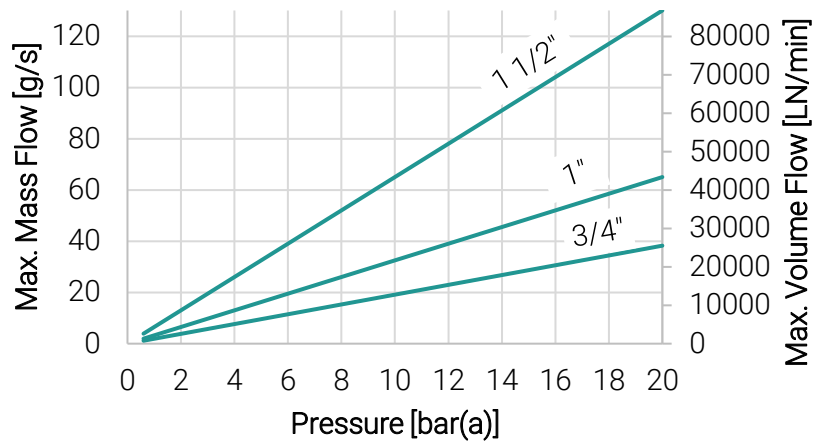

Mass Flow Accuracy  $\pm 4\%$  of measured value

Repeatability  $\pm 1\%$  of measured value

## Gas Composition Determination *Optional*

Method Ultrasonic Technology

Supported Gas Mixtures  
*others on request*

- Hydrogen H<sub>2</sub> – Nitrogen N<sub>2</sub> / Water Vapor H<sub>2</sub>O
- Hydrogen H<sub>2</sub> / Methane CH<sub>4</sub>

Accuracy  
*depending on mixing ratio H<sub>2</sub>/N<sub>2</sub>*

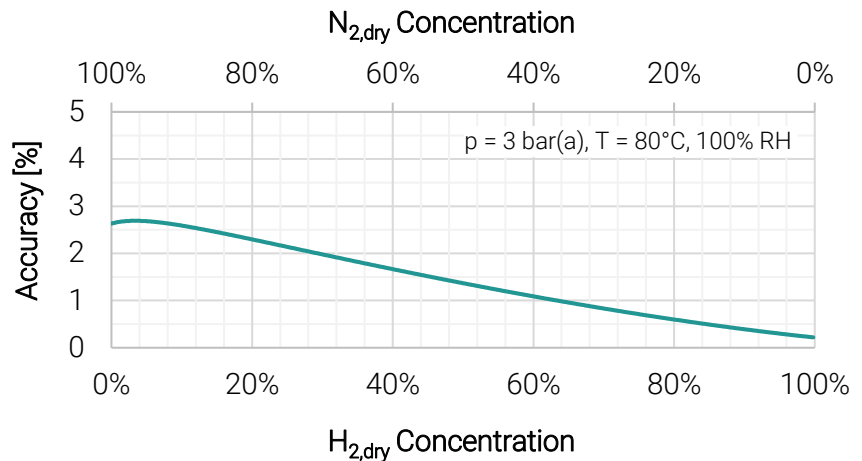

Output Volume [vol %] and Mass [wt %] fractions of each individual component

Designated Applications  
*others on request*

- PEM Fuel Cell Anode Recirculation
- Solid Oxide Fuel Cell fueled with H<sub>2</sub>-CH<sub>4</sub>
- Industrial Process Monitoring
- Electrolyzer Output Purity Measurement

# Hydrogen Flow Meter

For Fuel Cell Anode Inlet & Recirculation

## Electrical data

Power Supply	12 - 24 V
Current consumption	< 100 mA

## Electrical interface

Cable length	1.0 m
Electrical connection	Open cable ends
Interfaces	CAN, Modbus <i>others on request</i>

Cable color-coding  
Pinout

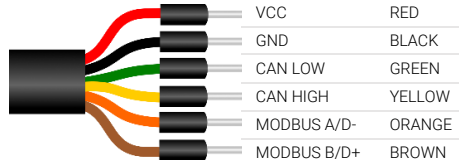

## CAN Bus interface

Standard	ISO 11898-2 (High-Speed Applications)
Message Format	2.0A (11 bit identifier)
Baud rate	500 kbit/sec <i>others on request</i>
Termination Resistor	Open
Base ID	0x190

## Modbus interface

Baud rate	115200 Baud Parity: Even Stopbits: 1
Parity	Even
Stopbits	1
Device ID	0x01

## Data Points

### Standard

- Velocity [m/s]
- Volume Flow [l/min]
- Volume Flow in Normal Conditions [l<sub>n</sub>/min]
- Temperature [°C]
- Pressure [bar]
- Mass flow [g/s]
- Humidity [% RH]
- Concentration Gas Components [vol %]
- *More on request*

Download CAN Database File (DBC) at <https://allengra.eu/products/hydrogen-flow-meter#variants>

# Hydrogen Flow Meter

For Fuel Cell Anode Inlet & Recirculation

## Dimensions

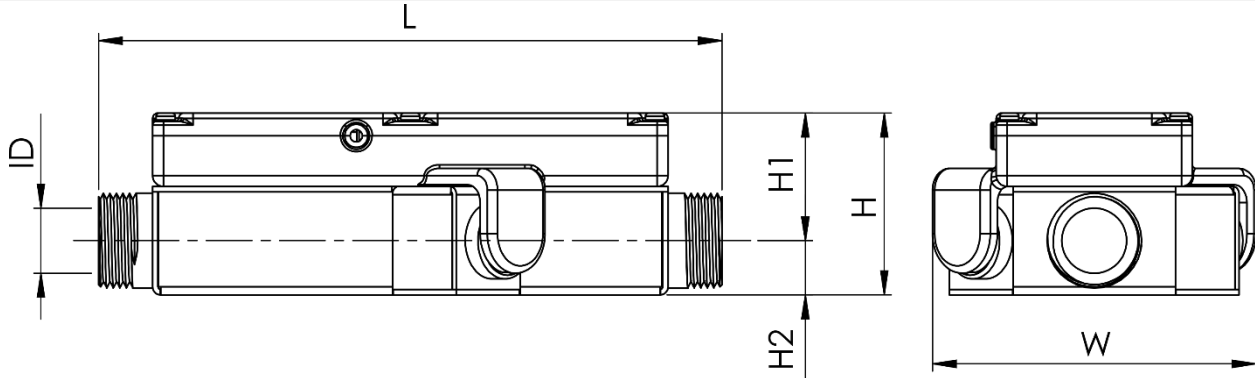

Dimension	3/4"	1"	1 1/2"
Inner Diameter ID	18	21	38
Thread G for flat seal	G3/4	G1	G1 1/2
Length L	173	173	210
Width W	90	100	112
Height H	50	55	86.3
Height H1	35	36.8	53.3
Height H2	15	18.2	33

## Installation notes

**Orientation** Recommended orientation horizontally with electronics cover facing upwards

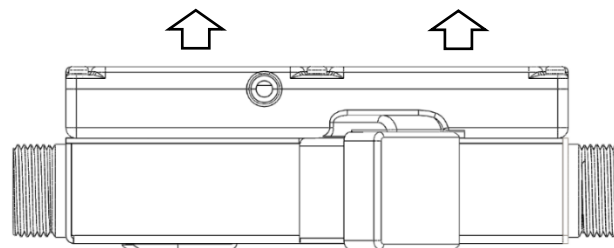

**Calming section** Ensure accurate readings with a calming section upstream 5x ID and downstream 1x ID of the sensor. Select the pipe ID according to the sensor dimensions.

## Pressure Loss

Pressure Loss  
for 3/4" variant

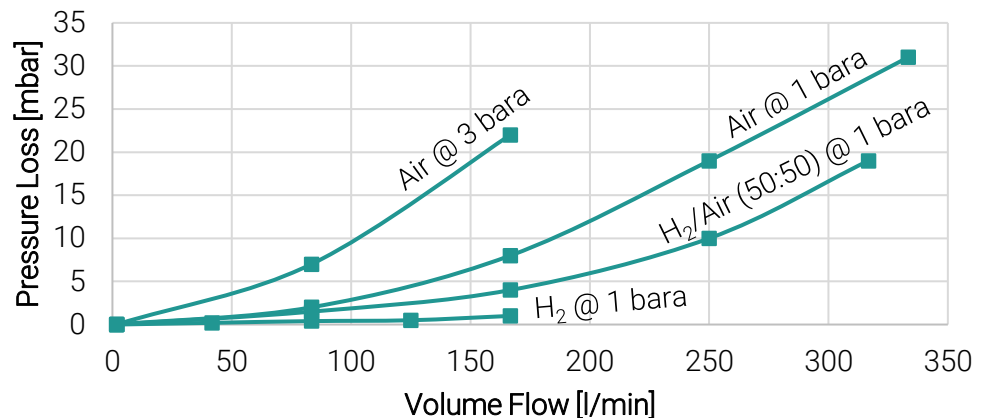

# Hydrogen Flow Meter

For Fuel Cell Anode Inlet & Recirculation

## Process Connections

Dimension	3/4"	1"	1 1/2"
Connection Type	G3/4" for flat seal	G1" for flat seal	G1 1/2" for flat seal

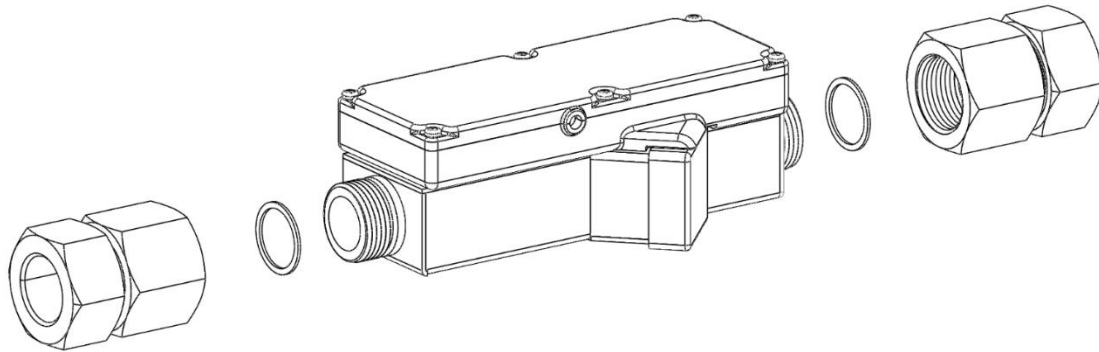

Recommendations for counterpart fittings

- Schwer Fittings SR-53022L | SR-53028L | SR-53042L
- Schwer Fittings DK-28022L | DK-28028L | DK-28042L

## Sealings

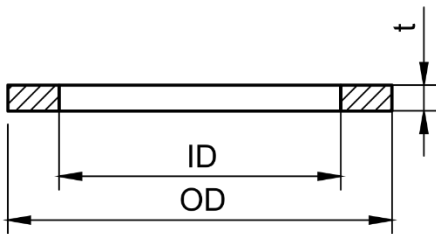

Hydraulic connection with flat seals *not included*  
 Choose ID of seal larger than sensor *see recommendation*  
 Align flat seal concentrically *no interference with free cross-section*

Dimension	3/4"	1"	1 1/2"
Recommended Flat Seal dimensions (ODxIDxt)	24x18x2	30x22x2	44x35x2

Additional sealant can be applied. Permabond F201HV recommended.

# Hydrogen Flow Meter

For Fuel Cell Anode Inlet & Recirculation



## About Us

Allengra GmbH, with headquarters in Germany and Romania, was established in 2005 and specializes in the design and production of standard or OEM ultrasonic flow sensors and control valves for liquids and gases, tailored to meet the specific needs of each end client application. Our company manages the entire development process, from concept to serial production, with various engineering departments and prototyping skills at our disposal.

Allengras core technology, ultrasonic metering, has been refined over the years to a level where both high-end device integration and cost-effective applications are achievable. Allengra provides metering and regulating solutions for various industries, including gas heating boilers, automatic coffee machines, robotic scrubbers, and industrial automation, among others.

## Über Uns

Die 2005 gegründete Allengra GmbH mit Sitz in Deutschland und Rumänien entwickelt und produziert sowohl Standard- als auch maßgeschneiderte Ultraschall-Durchflusssensoren und Regelventile für Flüssigkeiten und Gase. Allengra vereint alle notwendigen Engineering und Prototyping Fähigkeiten, um die Produkte interdisziplinär und ganzheitlich zu entwickeln. So können auch neue und innovative Ideen schnell und flexibel in robuste Serienprodukte überführt werden.

Allengras Kernkompetenz, die Ultraschall-Durchflussmessung, kann durch die umfangreiche und langjährige Erfahrung mit der Technologie problemlos sowohl in High-End-Produkte als auch in robuste und kostengünstige Serienlösungen integriert werden. Allengra bietet Mess- und Regelungslösungen für Anwendungen in Gasheizkesseln, Kaffeevollautomaten, Bodenreinigungsmaschinen, dem Motorsport, der industriellen Automatisierung und vieles mehr.