

FIM FUEL FLOW SENSOR

Product highlights

- **Compact** ultrasonic flow meter suitable for fuel flow measurement in World Superbike competition or other motorsport categories
- **Ultrasonic** flow meter with no moving parts subject to wear
- High **accuracy** and **repeatability**
- Flow measurement frequency 6 kHz
- **Anti-aliasing** features
- **Long lifetime** under rough operating conditions

Applications

- Motorsports
- World Superbike
- Motorbikes
- Quads
- Snowmobiles
- Karts

Description

Allengra FIM fuel flow sensor is tailored for operation in the fuel line of internal combustion engines under high vibrations and quick pulsating flow conditions. Without moving parts or components subject to wear, a long lifetime can be guaranteed.

1. Technical data

1.1. FLOW MEASUREMENT

Measurement element:	Ultrasonic transducers	
Measurement range:	+/- 5 – 1500 ml/min	+/- 0.3 – 90 L/h
Accuracy:	< +/- 0.5% of measured value	
Repeatability	< +/- 0.25%	
Response time:	< 3 ms	

1.2. TEMPERATURE MEASUREMENT

Measurement element:	2x Platinum chip resistor (PT1000)	
Measurement range:	0 – 110°C	
Accuracy:	0.3K	
Repeatability:	0.15K	
Response time:	T95 <2s	

1.3. PRESSURE MEASUREMENT

Measure element	Monolithic pressure sensor	
Measurement range:	-0.1 – 10 barG	
Accuracy:	± 0.1 bar	
Repeatability:	± 0.01 bar	
Response time:	< 100 ms	

2. Environmental data

2.1. OPERATING CONDITIONS

Mediums:	All types of gasoline blends
Operating temperature:	0 – 90°C
Thermal shock:	Up to 120 °C
Storage temperature:	- 40 – 80°C (without freezing liquids inside)
Operating pressure:	- 0.1 – 10 barG
Over pressure:	15 barG
Burst pressure:	25 barG
Protection class:	IP54
Relative humidity:	< 95% rh
Lifetime:	> 5 years (inspection > 1 year)

2.2. SUSTAINABILITY

RoHS:	Compliant
Reach:	Compliant

2.3. MATERIALS

Wetted parts:	AISI304, PPS 40% GF, PEEK, POM, Aluminium 7075, FFKM
Non-wetted parts:	POM, ABS, AISI304, Aluminium 7075

3. Electrical data

Supply voltage:	5.5 – 24 VDC
Current consumption:	<70 mA @ 12V <150mA @ 5.5V
Electrical connector:	Deutsch ASDD006-09-PA-FI-952K
Mating connector:	Deutsch ASDD606-09SA-FI-952K
PIN assignment:	1 – Supply +ve 2 – CAN +ve 3 – CAN -ve 4 – Reserved 5 – Reserved 6 – RS485 (ModBus A) 7 – RS485 (ModBus B) 8 – CAN Select (Loom resistor) 9 – GND

3.1. OUTPUT SIGNALS

CAN/CAN-FD	
Standard:	ISO 11898-2 (high-speed applications)
Message format:	2.0A (11 bit identifier)
Baud rate:	1 Mbit/sec
Termination resistor:	open
Base ID:	0x190
RS485	
Designation:	Firmware update and configuration

4. Mechanical

Hydraulic connections:	2x 6AN male (Optional 2x 4AN male)
Pressure loss:	~40 mBar @ 1000 ml/min, 25°C (depending on gasoline type)
Weight:	~200g (dry)
Fixation:	4x Ø4.2mm

4.1. DIMENSIONS

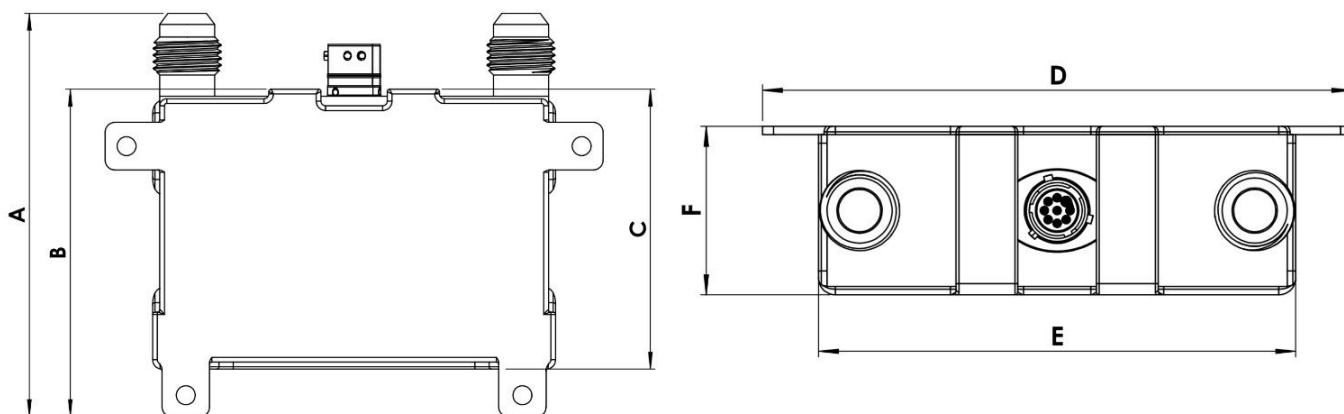

A	85 mm
B	69 mm
C	59 mm
D	105 mm
E	85 mm
F	30 mm

5. CAN Details

5.1. CAN Select (Loom resistor)

Loom detect resistors	Base ID
Open	0x190
10k	0x1A0
5k6	0x194
3k3	0x1A4
1k8	0x198
470R	0x19C

5.2. CAN message structure

Base ID + 0	
Message description:	Mass flow, Volume flow, Mass total
Message ID:	Base ID + 0
Message format:	Big Endian (MSB First)
Message rate:	100 Hz
Message Type:	Continuous Transmit @ message rate
Filter:	Filtered flow values (4th order low pass Butterworth with 25Hz – 3dB cut-off frequencies)

Byte 0	Byte 1	Byte 2	Byte 3	Byte 4	Byte 5	Byte 6	Byte 7
Volume flow (16 bit signed integer MSB first)		Mass flow (16 bit signed integer MSB first)		Total mass (32 bit signed integer)			
Base units: 0.5 ml/min per bit		Base units: 0.5 g/min per bit		Base units: 1g per bit			
Max: 16,384.0 ml/min Min: -16,384.0 ml/min		Max: 16,384.0 g/min Min: -16,384.0 g/min		MSB		LSB	

BASE ID + 1

Message description:	Multiplexed debug and diagnostics message
Message ID:	Base ID + 1
Message format:	Big Endian (MSB First)
Message rate:	100 Hz
Message Type:	Continuous Transmit @ message rate

Byte 0	Byte 1	Byte 2	Byte 3	Byte 4	Byte 5	Byte 6	Byte 7
Speed of sound, 0.1 m/s/bit		0	CAN ID select (1, 2, 3, -)	Fuel temperature (0.01 degC/bit signed)	PCB temperature (0.1degC/bit signed)		
		1	CPU SW Version	Min fuel temperature (0.01degC/bit signed)	Max fuel temperature (0.01degC/bit signed)		
		2		Min PCB temperature (0.1degC/bit signed)	Max PCB temperature (0.1degC/bit signed)		
		3	Boot SW version	Hardware version (unsigned)	Supply voltage (0.1V/bit unsigned)		
		4		Diagnostics bitword (unsigned)	Seconds from hardware reset (s unsigned)		
		5	SW programming counter	Latched diagnostics bitword (unsigned)	Total time with flow / Service Indicator (min unsigned)		
		6	Calibration calibration counter	Manufacturer status bitword (unsigned)	Elapsed time indicator (min unsigned)		
		7		Sensor serial number (unsigned)	resistor sense input voltage (0.01V/bit unsigned)		
		8	Density calibration counter	CPU software checksum (unsigned)	density calibration checksum (unsigned)		
		9	Reserved	Bootloader checksum (unsigned)	density value in use (0.1kg/m3/bit, unsigned)		
		10 (A)	Product identification	Configuration checksum (unsigned)	Reference density at a reference temperature (0.1kg/m3/bit, unsigned)		
		11 (B)		Calibration checksum (unsigned)	Reference temperature for density calibration (0.1degC/bit unsigned)		
		12 (C)			Slope (Density vs temperature) (0.001 kg/m3/degC/bit signed)		
		13 (D)					
	14 (E)						
	15 (F)						
	16 (10)						
	17 (11)						
	18 (12)						
	19 (13)						



About Allengra

Allengra GmbH based in Germany and Romania, founded in 2005, is capable to develop and produce standard or OEM devices for ultrasonic flow sensors and control valves for liquids and gases, tailored on the end client application.

The complete development and manufacturing processes are carried out in our company and we are able to transform an idea into a robust serial product thanks to the various engineering departments and prototyping skills.

The core technology of Allengra, ultrasonic metering has been refined over the years to a level where both integration into high-end devices and cost-effective applications are possible.

Do you have a project that needs a flow, temperature, pressure measurement or an electric valve?

Do not hesitate to contact us at info@allengra.eu for a solution.
